

WL52

Articulated Wheel Loaders



**WACKER
NEUSON**
all it takes!



Versatility, power and performance

The WL 52 articulated wheel loader is the ideal machine for a variety of jobs. It is equipped with a 74-HP turbo charged Deutz T4F diesel engine. With standard auxiliary hydraulic flow of 18 gpm and high flow of 33 gpm (optional) allows for operation of high performance attachments. With travel speeds up to 19 mph, getting around the jobsite is extremely efficient. The operator's station is ergonomically laid out for the comfort and convenience of the operator, reducing fatigue and increasing productivity. Operating elements including a multifunctional single lever control and an additional lever for the third control circuit, are conveniently arranged next to the driver's seat for easy operation.

- Deutz Tier 4 Final, 74-hp engine offers a maintenance-free aftertreatment
- The tilting driver's cab provides optimum service access
- Universal hydraulic attachment plate allows flexibility for use of current and new attachments
- Faster quick connect hydraulic connector provides quick and easy changing of attachments
- A 14-pin wiring harness allows the operator to control multiple attachment functions simply from the unit's single joystick

WL52 Technical specifications

Engine / Motor

Engine / Motor manufacturer	Deutz
Engine / Motor type	TCD 2.9 L4
Cylinder	4
Engine performance	75 hp
at rpm maximum	2,300 rpm
Displacement	177 in ³
Coolant type	Water / Charge Air

Electrical system

Operating voltage	12 V
Battery	95 Ah
Alternator	95 A

Weights

Operating weight	11,243.5 lb
Lifting force maximum	6,755.5 lb
Breakout force maximum	9,538.6 lbf

Vehicle data

Bucket capacity Standard bucket	0.981 yd ³
Traction drive	Hydrostatic with universal joint shaft
Axles	PA 1400
Drivers cab	Cabin
Speed (standard)	0-12.43 mph
Speed (optional)	0-18.6 mph
Speed Level	2
Standard tires	405/70-18 EM ET 0

Hydraulic system

Driving hydraulics - operating pressure	6,454.28 psi
Operating hydraulics - operating pressure	3,335.92 psi
Operating hydraulics - discharge capacity	15 US gpm
Operating hydraulics - discharge capacity (optional up to)	30.16 US gpm

Filling capacities

Tank capacity (fuel)	21.3 US gal
Hydraulic oil tank	69.7 US qt

Sound level

Average sound power level LwA	103.3 dB(A)
Guaranteed sound power level LwA	101 dB(A)
Specified sound pressure level LpA	78 dB(A)

Standard bucket = digging bucket, width 1900 mm (75 in)

WL52 Dimensions

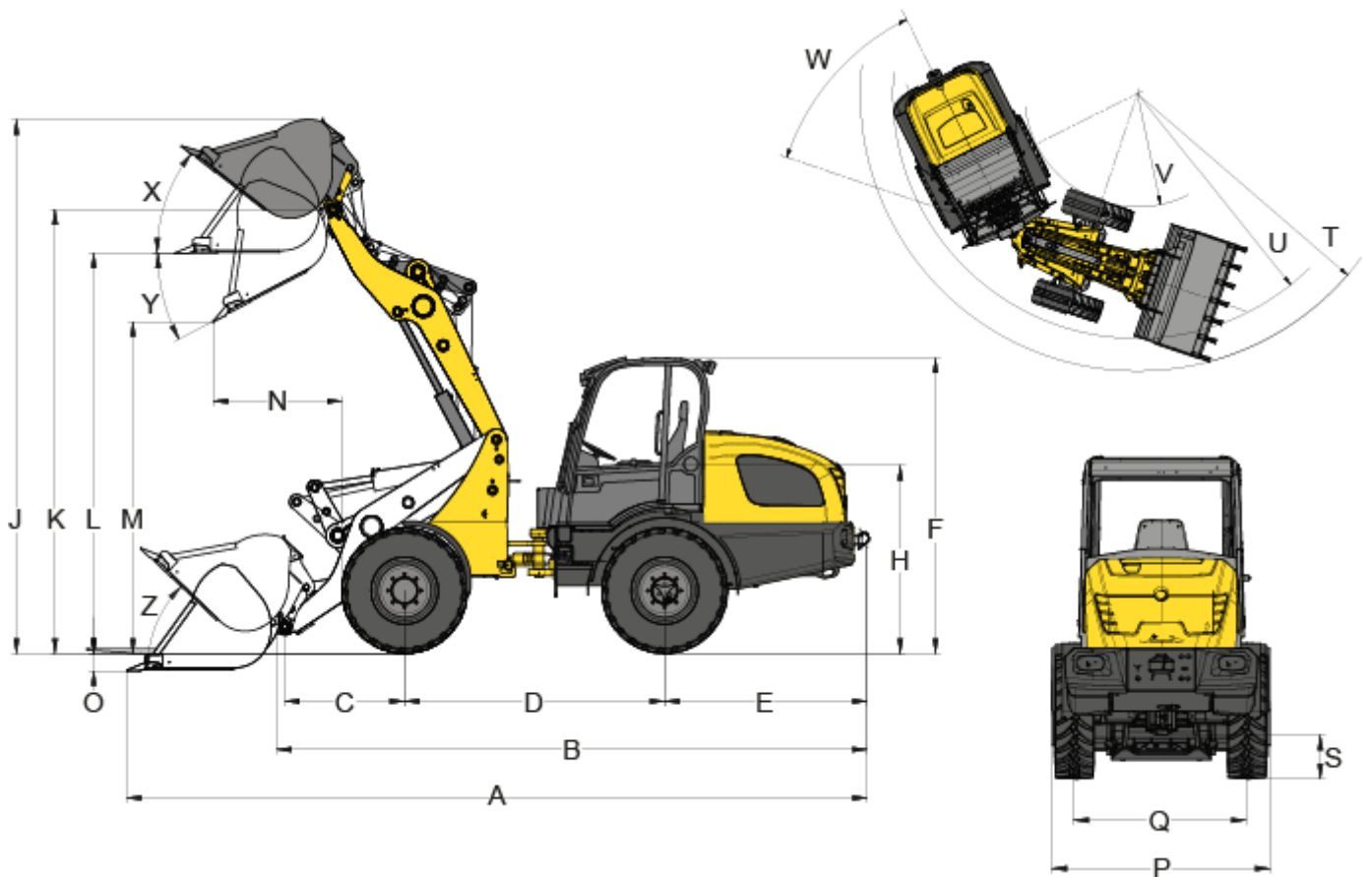

	Standard tires	405/70-18 EM ET 0
A	Overall length	216.1 in
B	Overall length without bucket	183 in
C	Bucket pivot point to axle center	40.4 in
D	Wheelbase	79.1 in
E	Rear overhang	60.3 in
F	Height with cab	103 in
H	Seat height	61.4 in
J	Total operating height	158.5 in
K	Stroke height max. - bucket pivot point	132.2 in
L	Overhead loading height	119.3 in
M	Dump height max.	99.3 in
N	Range at M	24.6 in
O	Scraping depth	4.4 in
P	Overall width	73.8 in
Q	Track width	53.6 in
S	Ground clearance	14.3 in
T	Radius maximum	155.2 in
U	Radius at outer edge	136.3 in
V	Inside turning radius	60.6 in
W	Articulation angle	42 °

X	Bucket rollback at max. stroke height	44 °
Y	Dump angle maximum	39 °
Z	Bucket rollback at ground level	43 °

All values with standard bucket and standard tires

Please note: that product availability can vary from country to country. It is possible that information / products may not be available in your country. More detailed information on engine power can be found in the operator's manual; the stated power may vary due to specific operating conditions. Subject to alterations and errors excepted. Applicable also to illustrations.

Copyright © 2021 Wacker Neuson SE.